

 **ITALIANA**[®]
f e r r a m e n t a

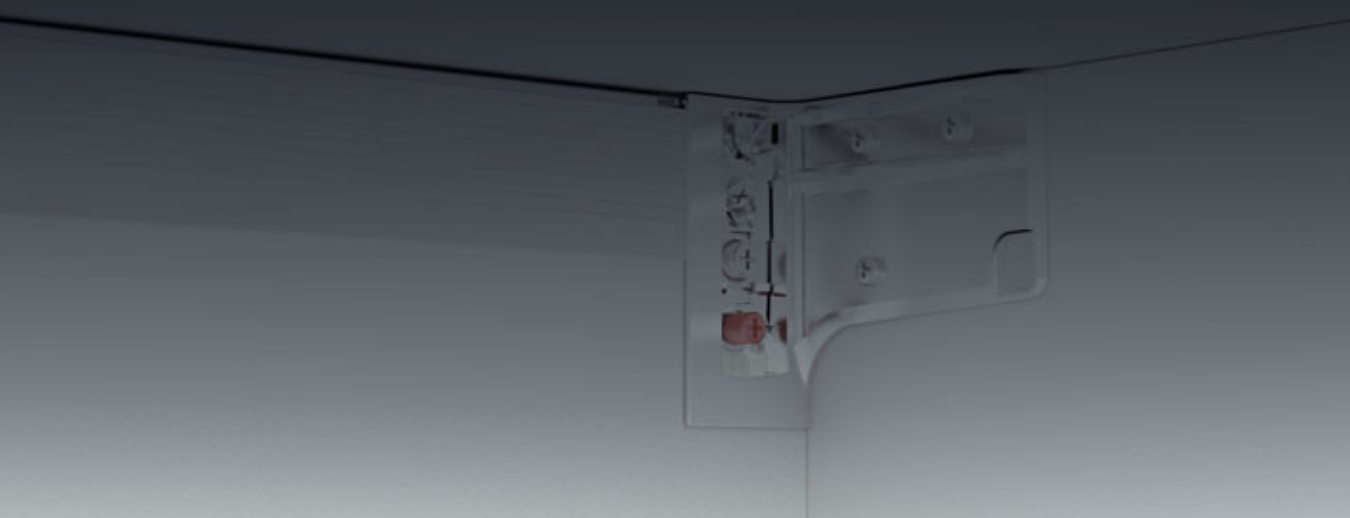

Libra H7



HANGERS



SYMBOLS AND FINISHES LEGEND

SYMBOLS

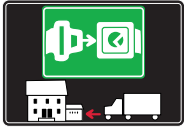

= SHELF SAFELY LOCKED DURING TRANSPORTATION AND AT HOME.



= ANTI-TURNOVER LOCKING SYSTEM



= NORMS / PATENTS



= PHILLIPS / POZIDRIV



= WITH BUFFER



= PART NO.



= BLADE SLOT



= WITH MAGNET



= PCS. PER PACKAGE



= COMBI SLOT



= HEXAGONAL SOCKET



= NEWTON



= CAPACITY LOADING



= HEXALOBULAR SOCKET



= FRICTION



= WOOD / GLASS THICKNESS



= COUNTERSUNK HEAD



= AUTOMATIC



= HOLE DIAMETER



= PAN HEAD



= DROP DOWN



= DIAMETER



= FLANGE HEAD



= LENGTH



= FLAT HEAD



= STANDARD HINGE



= HEIGHT



= TRILOBULAR SCREW



= KIMANA HINGE



= RIGHT VERSION



= SELF-TAPPING SCREW



= FLAP HINGE



= LEFT VERSION



= EURO THREAD



= WITH SPRING



= SETTING CODE



= METRIC THREAD



= WITHOUT SPRING



= PCS. PER PAD



= PRE-INSERTED SCREW



= REVERSED SPRING



= CUT ON REQUEST



= PRE-INSERTED SCREW AND SPREADING BUSH



= SELF ADHESIVE



= WITH FLANGE

NOTE: Printing errors and omissions may exist despite our best efforts to ensure accuracy. We reserve the right to alter specifications without notice.

MATERIALS

ZA = Zinc Alloy

ST = Steel

HSS = High Speed Steel

BR = Brass

ABS = Acrylonitrile Butadiene Styrene

ZAnk = Nickel-plated Zinc Alloy

STzk = Zinc-plated Steel

AL = Aluminium

WD = Wood

EVA = Ethylene Vinyl Acetate

EP = **ENGINEERING PLASTIC**

+ **EP** = other engineering plastic available on request

SR = **SOFT RUBBER**

+ **SR** = other soft rubber available on request

EPn = Natural Engineering Plastic

EPc = Clear Engineering Plastic

SRn = Natural Soft Rubber

EPw = White Engineering Plastic

EPg = Grey Engineering Plastic

SRw = White Soft Rubber

EPwg = Water Green Engineering Plastic

SRb = Black Soft Rubber



FINISHES



+ **OTHER FINISHES AVAILABLE ON REQUEST**

PART NO.	FINISHES	PART NO.	FINISHES	PART NO.	FINISHES
00	Insignificant finish	IF	Middle Grey	UT	T-Met 9007
AA	Natural	IJ	Light Grey	UZ	T-Met
AB	White	IL	Grey 20	WA	Bronzed
AE	White 9010	IN	Grey met. 26	WI	Burnished
EA	Black	JB	Bright Aluminium	XD	Satin-finished Steel
EC	Matt Black	JC	Aluminium - Chrome	YA	Nickel-plated
EE	Anthracite	JD	Matt Aluminium	YB	Bright Nickel-plated
EW	Grey 9007	JE	Satin-finished Aluminium	YC	Matt Nickel-plated
FU	Gunmetal	JF	Aluminium - Brass	YD	Satin-finished Nickel-plated
FV	Gunmetal V52	JG	Aluminium 5	YQ	Black Nickel
GR	Raw	JL	Aluminium PE 11	Z9	Black Zinc
HA	Brass-Plated	JM	Aluminium RAL 9006	ZA	Zinc alloy
HH	Tropicalized	KA	Chrome	ZN	Zinc-plated
HL	Raw Brass	KB	Bright Chrome	ZQ	Bright Gold
HX	Graphite	KC	Matt Chrome	ZY	Titanium
IA	Grey	NN	Metallic Beige	ZZ	Clear
IB	Metallic Grey	RO	Red		

LIBRA H7 APPLICATIONS: SCREW FIXING and DOWEL FIXING WITH OPTIONAL ALUMINIUM BARS

BENEFITS OF LIBRA H7 HANGING SYSTEM:

- Vertical and in-depth adjustments as well as the locking of the cabinet, can be easily and smoothly carried out from the inside.
- The hanging system is never interfering with the slides for drawers thanks to the slim side bracket wings.
- Absolutely no mills, nor grooves required on the side panels.

In the **current absence of a unifying European norm** which sets the standards for testing procedures aimed at defining capacity loadings of hanging systems conceived for suspended base units, we Italiana Ferramenta have simulated some of the most critical scenarios. The following simulations are meant to give our customers valid reference points concerning cabinet dimensions, weights, recommended loading capacity even when loaded drawers are opened.

The reported data, empirically obtained, exclusively refer to the constructions and examples shown, correctly positioned and assembled by using WP5 wall plate.

The customer must ensure that the wall is of suitable quality and structure.

Other important factors to be taken into consideration are determined by:

- the type of side panel, the actual thickness and the material used.
- the type and dimensions of the screws used.
- the actual positioning, depth and width of the groove milled for the back side installation.
- the capacity loading of the drawer slides used as well as the actual construction of the drawer.

We always recommend to test a complete cabinet.

For cases which differ from the ones reported, please contact us.

LIBRA H7 SCREW FIXING



LIBRA H7 DOWEL FIXING

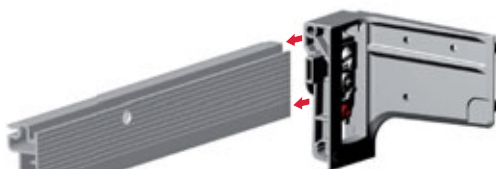

WITH ALU BAR H. 40,2

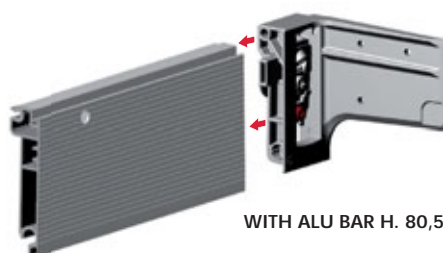

WITH ALU BAR H. 80,5

LIBRA WP5

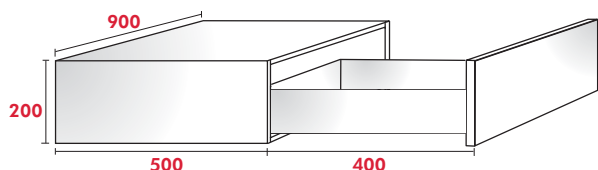

CAPACITY LOADING			
LIBRA H7 AND CABINET WITH STRUCTURAL TOP		FURNITURE TYPE	LIBRA H7 DOWEL FIXING AND ALU BAR H 40,2 WITH 2 EXTRA HANGING POINTS
SCREW FIXING	DOWEL FIXING		
120 Kg	120 Kg	Cabinet	160 Kg
80 Kg + 30 Kg	80 Kg + 30 Kg	Cabinet + drawer	120 Kg + 30 Kg

The reported data, empirically obtained, exclusively refer to the constructions and examples shown, correctly positioned and assembled by using WP5 wall plate.

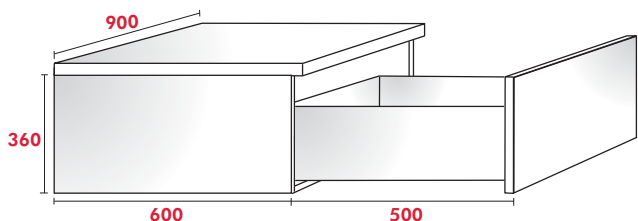

CAPACITY LOADING			
LIBRA H7 AND CABINET WITH STRUCTURAL TOP		FURNITURE TYPE	LIBRA H7 DOWEL FIXING AND ALU BAR H 40,2 WITH 2 EXTRA HANGING POINTS
SCREW FIXING	DOWEL FIXING		
160 Kg	150 Kg	Cabinet	180 Kg
120 Kg + 30 Kg	110 Kg + 30 Kg	Cabinet + drawer	140 Kg + 30 Kg

The reported data, empirically obtained, exclusively refer to the constructions and examples shown, correctly positioned and assembled by using WP5 wall plate.

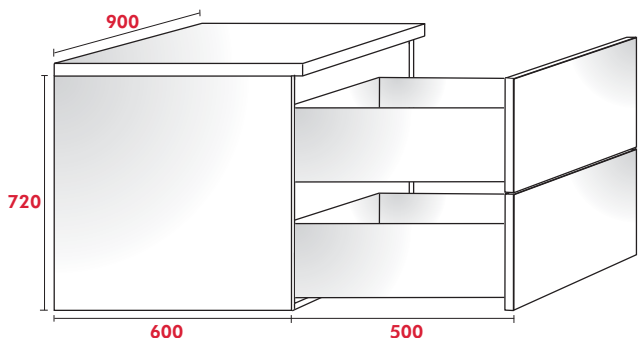

CAPACITY LOADING			
LIBRA H7 AND CABINET WITH STRUCTURAL TOP		FURNITURE TYPE	LIBRA H7 DOWEL FIXING AND ALU BAR H 40,2 WITH 2 EXTRA HANGING POINTS
SCREW FIXING	DOWEL FIXING		
200 Kg	170 Kg	Cabinet	210 Kg
130 Kg + 60 Kg	100 Kg + 60 Kg	Cabinet + drawer	140 Kg + 2 x 30 Kg

The reported data, empirically obtained, exclusively refer to the constructions and examples shown, correctly positioned and assembled by using WP5 wall plate.

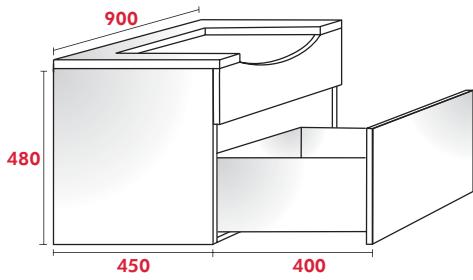

CAPACITY LOADING 			
LIBRA H7 AND CABINET WITH STRUCTURAL TOP		FURNITURE TYPE	LIBRA H7 DOWEL FIXING AND ALU BAR H 40,2 WITH 2 EXTRA HANGING POINTS
SCREW FIXING	DOWEL FIXING		
200 Kg	170 Kg	Cabinet	210 Kg
160 Kg + 30 Kg	130 Kg + 30 Kg	Cabinet + drawer	170 Kg + 30 Kg

The reported data, empirically obtained, exclusively refer to the constructions and examples shown, correctly positioned and assembled by using WP5 wall plate.

The hanging system is never interfering with the slides for drawers thanks to the slim side bracket wings.

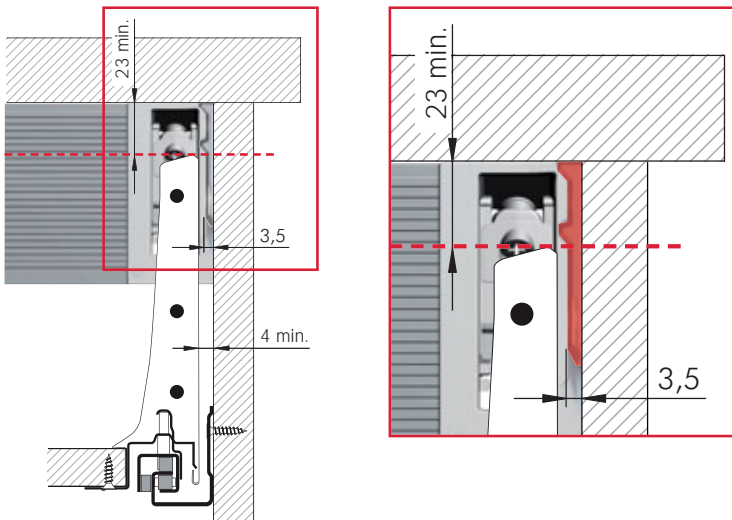

Easy access to the adjustments

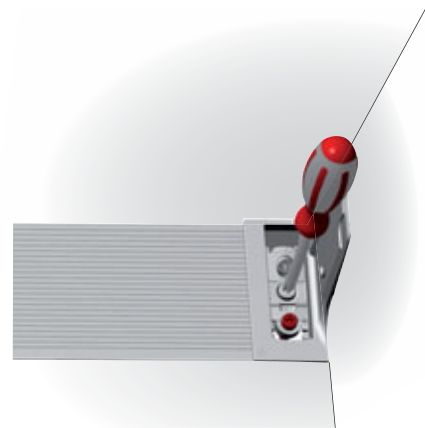

The slim side bracket makes the use of tools very easy and comfortable as there is plenty of space between the side and the screwdriver.

 = STRESS INTENSITY LEVEL ON THE WALL

By adding extra hanging points on the aluminium bar, the capacity loading is more evenly distributed, thus sensibly reducing the stress intensity level on the wall.

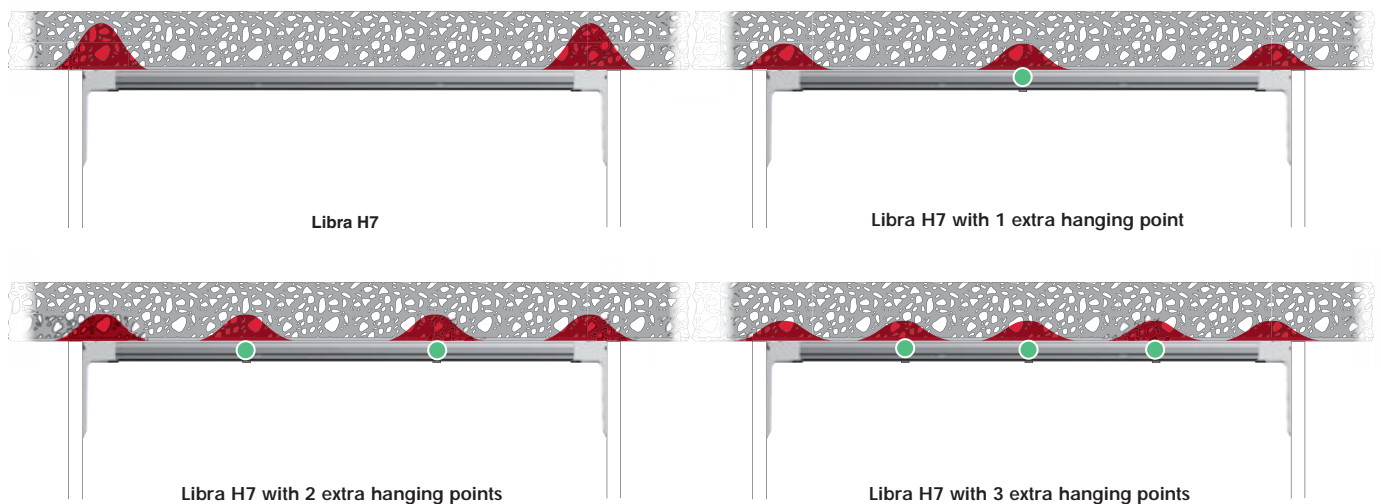

LIBRA H7 is a strong and versatile cabinet hanger especially designed for wall-mounted cabinets with heavy loads or particularly deep drawers. It is the ideal choice for vanity, kitchen or bathroom cabinet, or commercial display project.

The main benefits of LIBRA H7 are the following:

- Vertical and in-depth adjustments, with integrated locking of the cabinet, can be easily and smoothly carried out from the inside;
- The hanging system is never interfering with the slides for drawers thanks to the slim side bracket wings. Therefore also the use of tools is very easy and comfortable as there is plenty of space between the side and the screwdriver.
- Absolutely no mills, nor grooves are required on the side panels.

LIBRA H7 has two applications: with SCREW FIXING and DOWEL FIXING.

Both version can be mounted with optional aluminium bars. By adding extra hanging points on the aluminium bar, the capacity loading is more evenly distributed, thus sensibly reducing the stress intensity level on the wall.

In the current absence of a unifying European norm which sets the standards for testing procedures aimed at defining capacity loadings of hanging systems conceived for suspended base units, Italiana Ferramenta has simulated some of the most critical scenarios. The results of the empirical tests are available in the related brochure.

LIBRA H7 SCREW FIXING LIVING SETTINGS





LIBRA H7 SCREW FIXING



INSTALLATION UNDER THE CABINET TOP

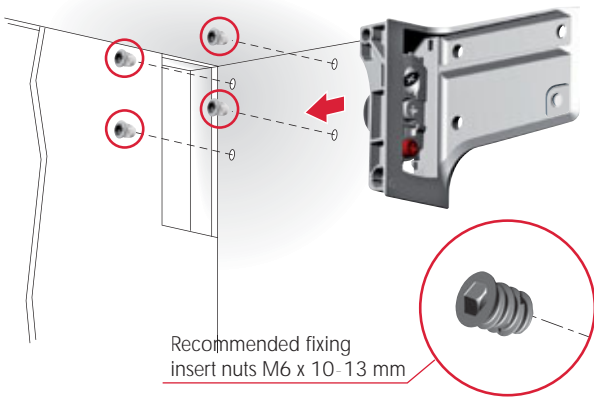

Recommended fixing flat head screws M6 x 12 mm

ALTERNATIVE APPLICATION WITHOUT TOP

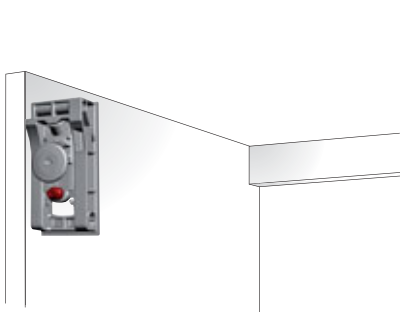

INSTALLATION ON THE WALL

- For details refer to "LIBRA WALL PLATES: LIBRA WP5"

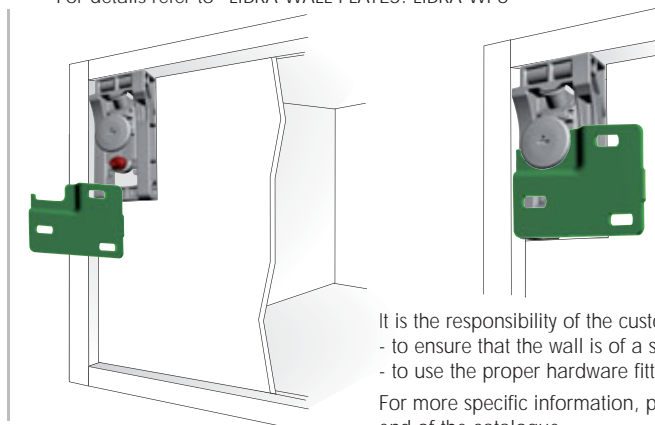

It is the responsibility of the customer:
 - to ensure that the wall is of a suitable quality to hold the unit fixing in place.
 - to use the proper hardware fittings according to the construction of the wall.
 For more specific information, please refer to the WARNINGS section at the end of the catalogue.

ADJUSTMENTS

1
VERTICAL ADJUSTMENT
13 mm

2
IN-DEPTH ADJUSTMENT
12 mm

3
ANTI-TURNOVER LOCKING
Stop screwing the red bolt when it touches the wall plate



Slot for cross PZ2 screwdriver

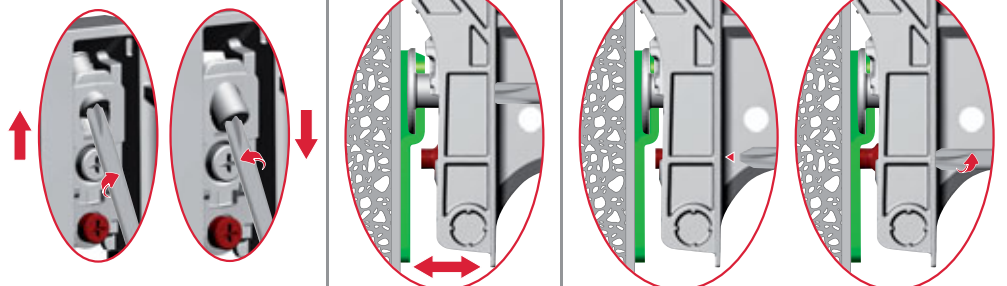
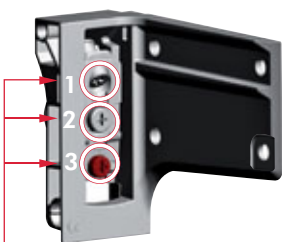

DRILLING PLAN WITH BACK PANEL WOOD THICKNESS 4 - 14 MM

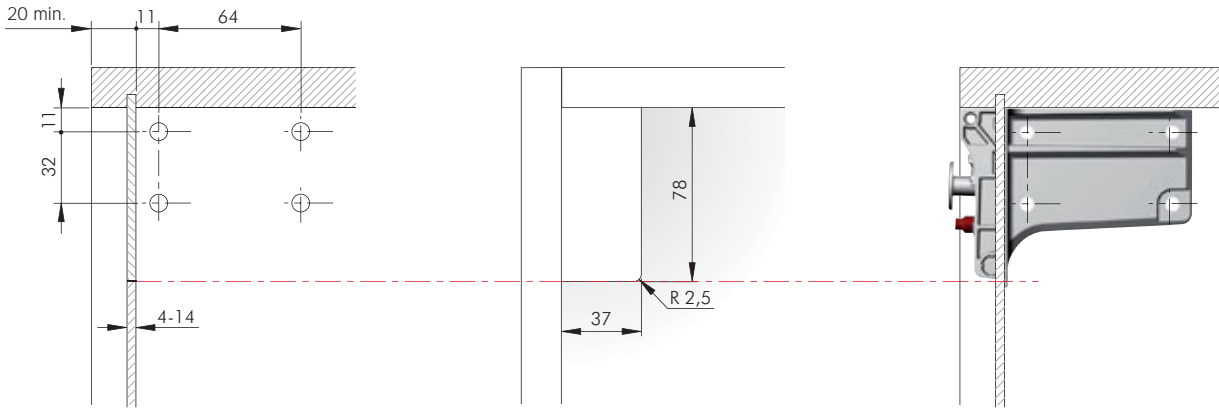

DRILLING PLAN WITHOUT BACK PANEL

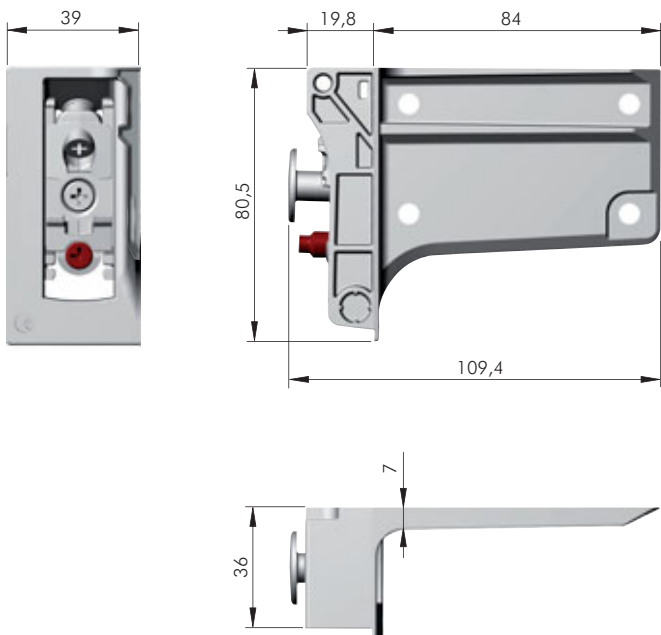
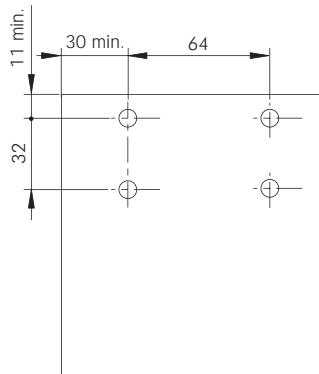

	= PZ2		= 50 pcs.
ZA	ST		
		(R)	
63422260ZN		(L)	
63422270ZN			



LIBRA H7 SCREW FIXING ACCESSORIES

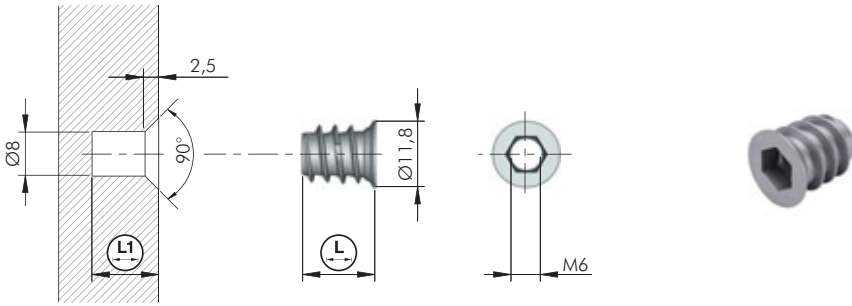

= Ø 8 mm	= M6	
	= S6	
	= 5000 pcs.	
123		
20102010GR	10	12
20102020GR	13	15



= M6	= PZ2	
		= 5000 pcs.
123		
20819020ZN		

LIBRA H7 DOWEL FIXING WITH ALUMINIUM BAR LIVING SETTINGS





LIBRA H7 DOWEL FIXING WITH "PEG JOINT" FOR ALUMINIUM BAR



ASSEMBLING WITH OPTIONAL ALUMINIUM BAR H. 40,2 MM OR H. 80,5 MM

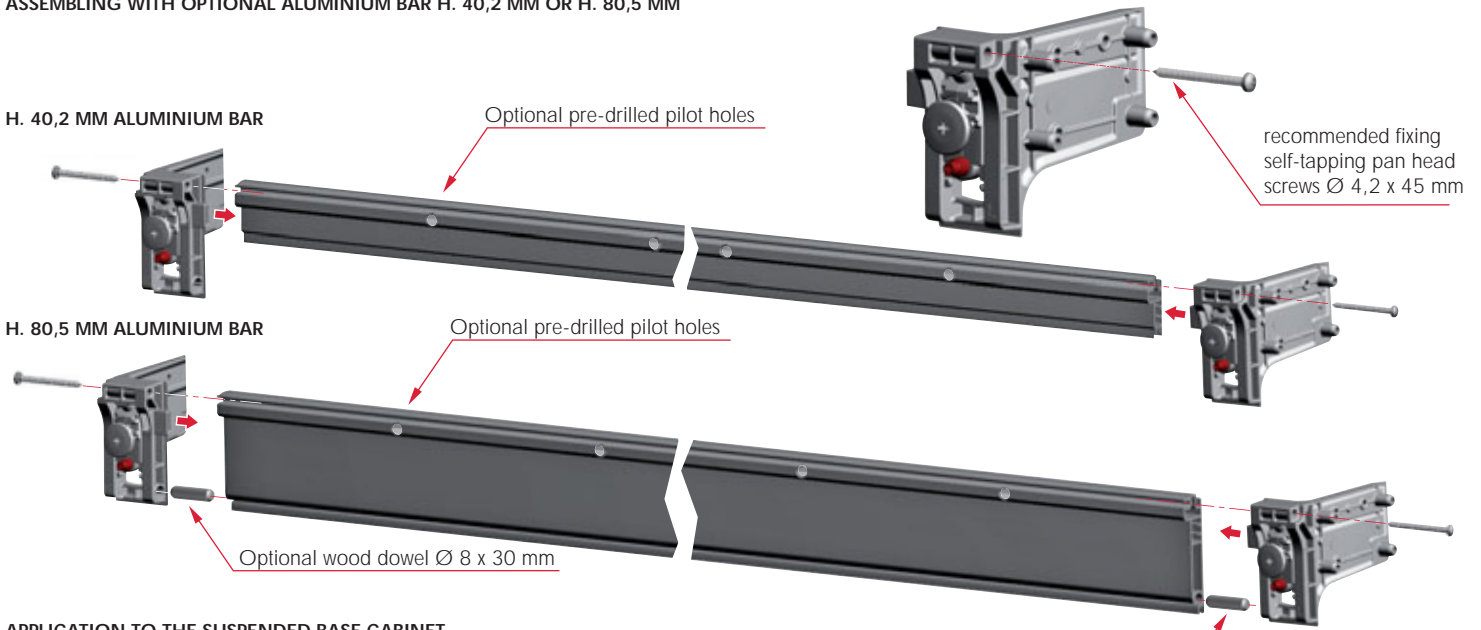

APPLICATION TO THE SUSPENDED BASE CABINET

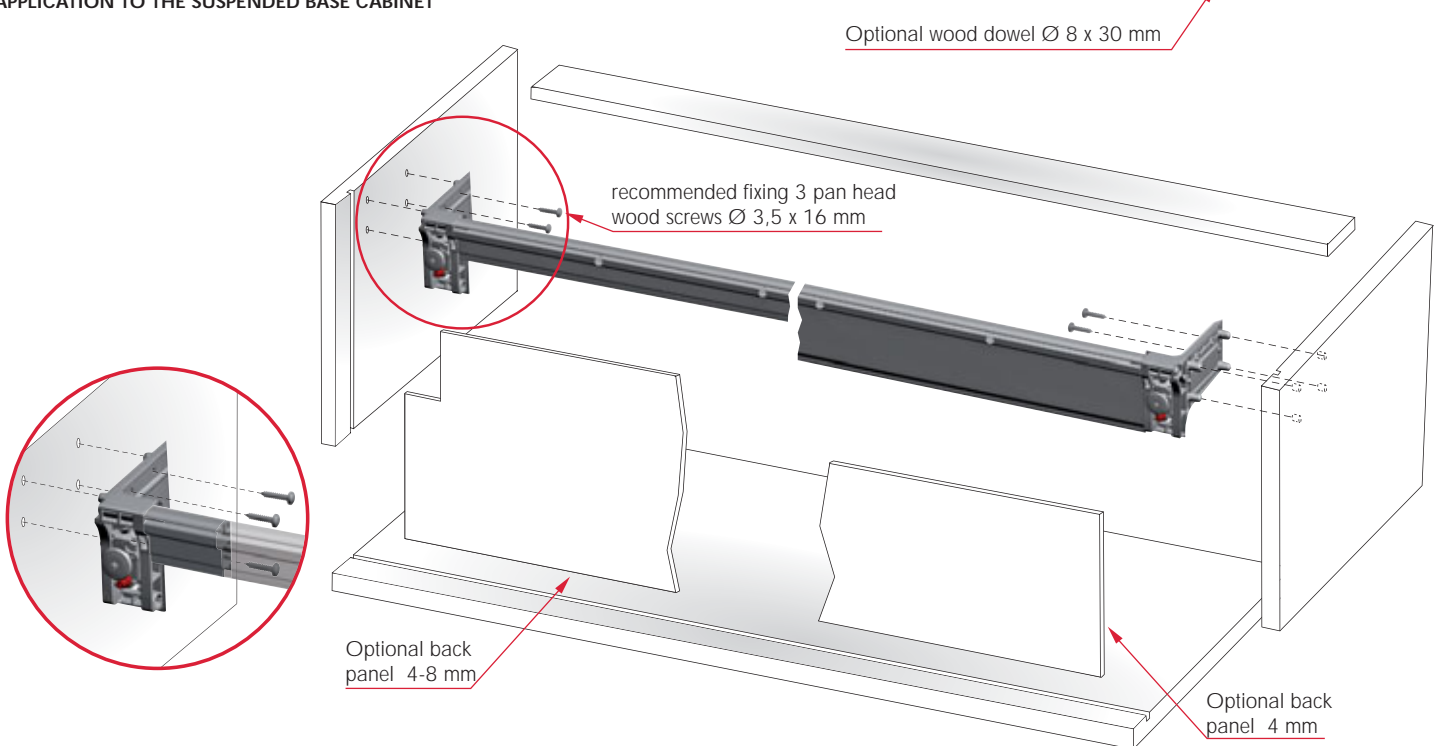

INSTALLATION ON THE WALL

- For details refer to "LIBRA WALL PLATES: LIBRA WP5"

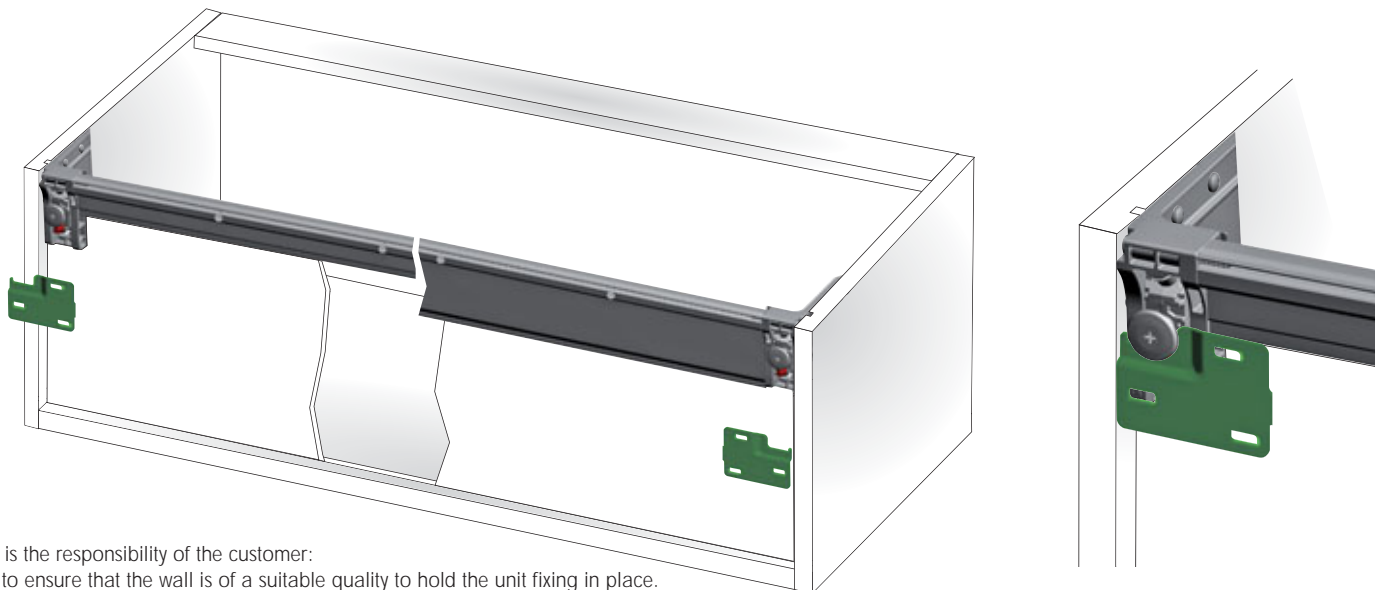

It is the responsibility of the customer:

- to ensure that the wall is of a suitable quality to hold the unit fixing in place.
- to use the proper hardware fittings according to the construction of the wall.

For more specific information, please refer to the WARNINGS section at the end of the catalogue.

ADJUSTMENTS (STEP 1)

1
VERTICAL ADJUSTMENT
13 mm

2
IN-DEPTH ADJUSTMENT
12 mm

3
ANTI-TURNOVER LOCKING
Stop screwing the red bolt when
it touches the wall plate

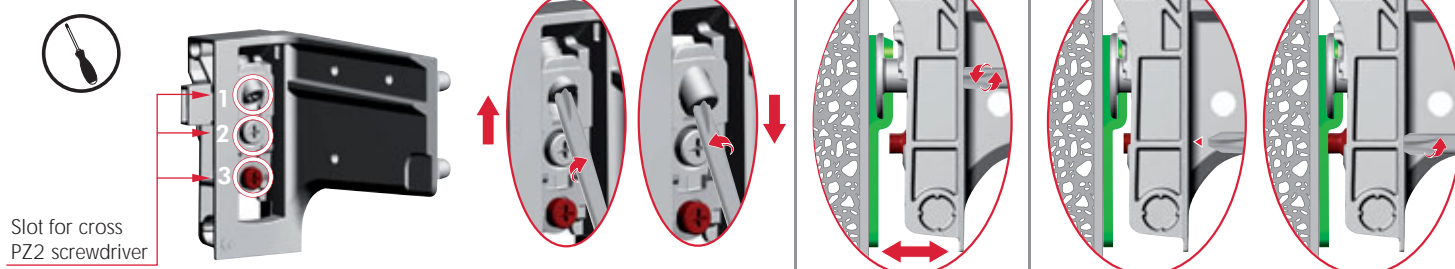

EXTRA HANGING POINTS (STEP 2)

The pre-drilled pilot holes ease the drilling operations on the wall.

Extra hanging points reduce the loading stress on the left/right wall plates.

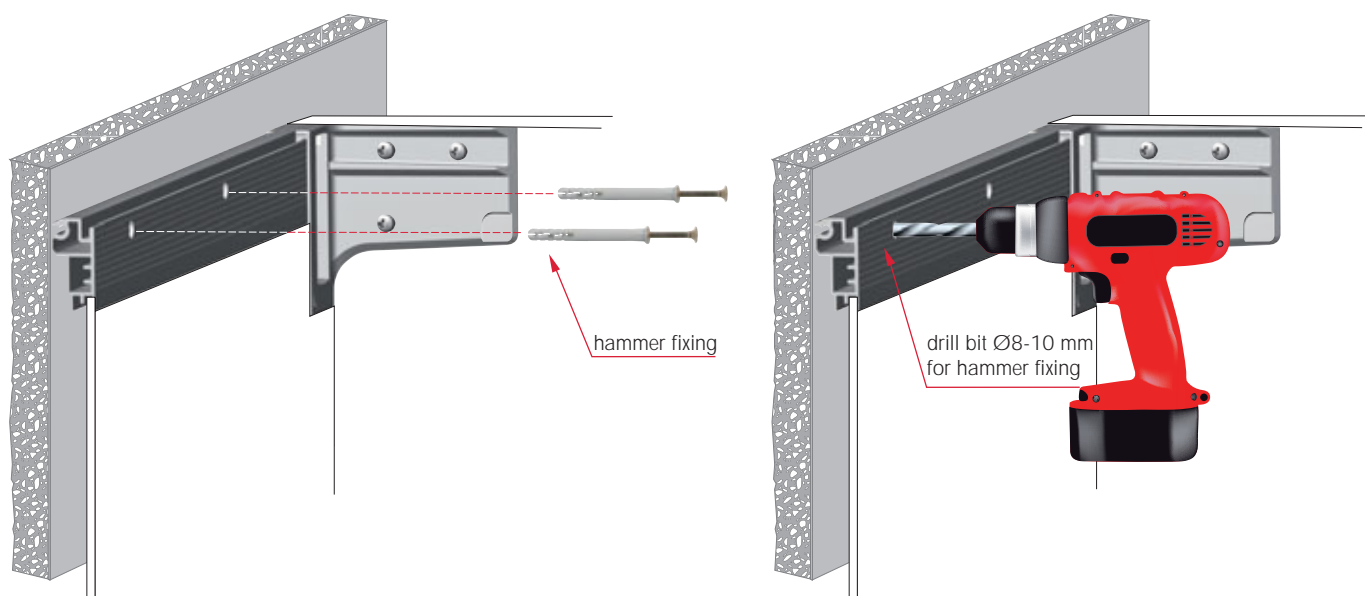



SIDE PANEL 15 MIN

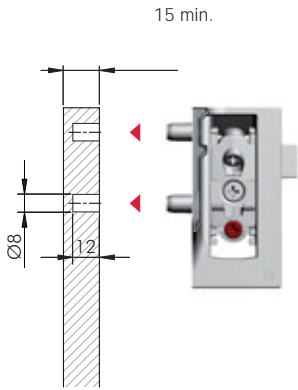

DRILLING PLAN WITHOUT BACK PANEL

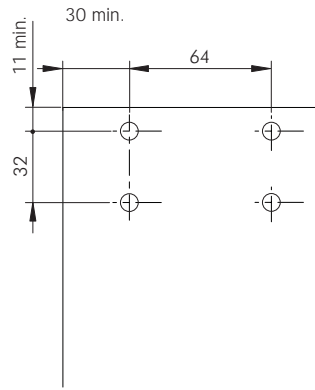

DRILLING PLAN WITH BACK PANEL WOOD THICKNESS 4 MM

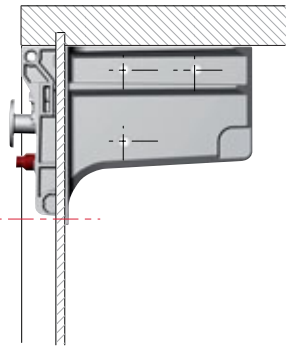
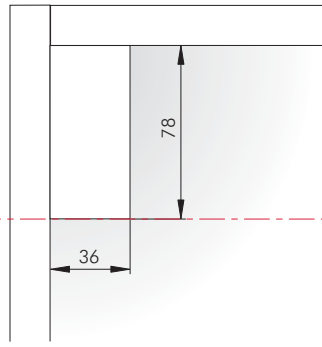
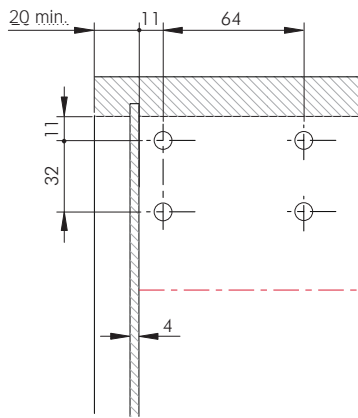

DRILLING PLAN WITH BACK PANEL WOOD THICKNESS 4 MM AND H. 40,2 MM ALUMINIUM BAR

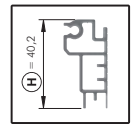
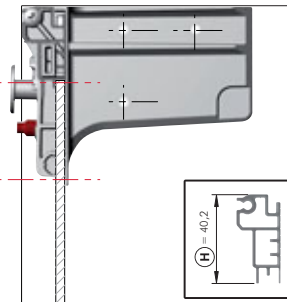
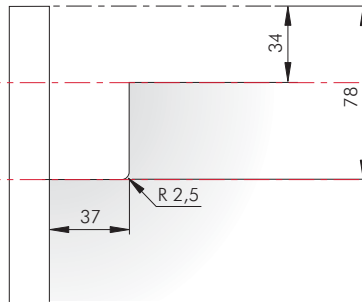
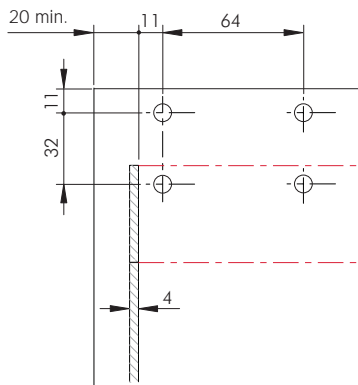

DRILLING PLAN WITH BACK PANEL WOOD THICKNESS 8 MM AND H. 40,2 MM ALUMINIUM BAR

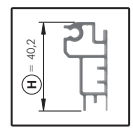
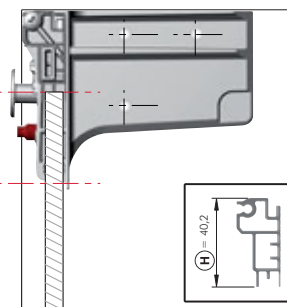
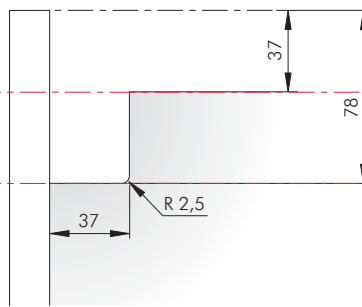
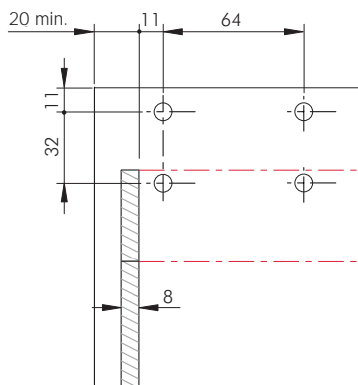

DRILLING PLAN WITH BACK PANEL WOOD THICKNESS 4 MM AND H. 80,5 MM ALUMINIUM BAR

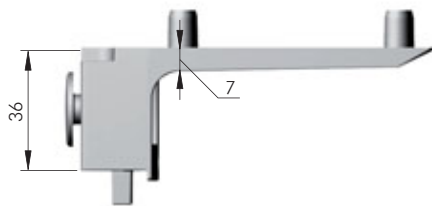
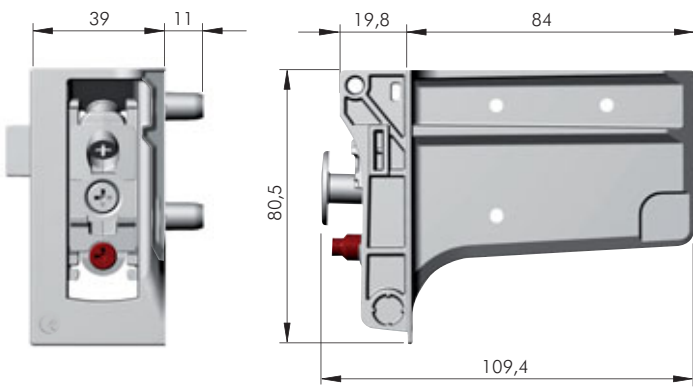
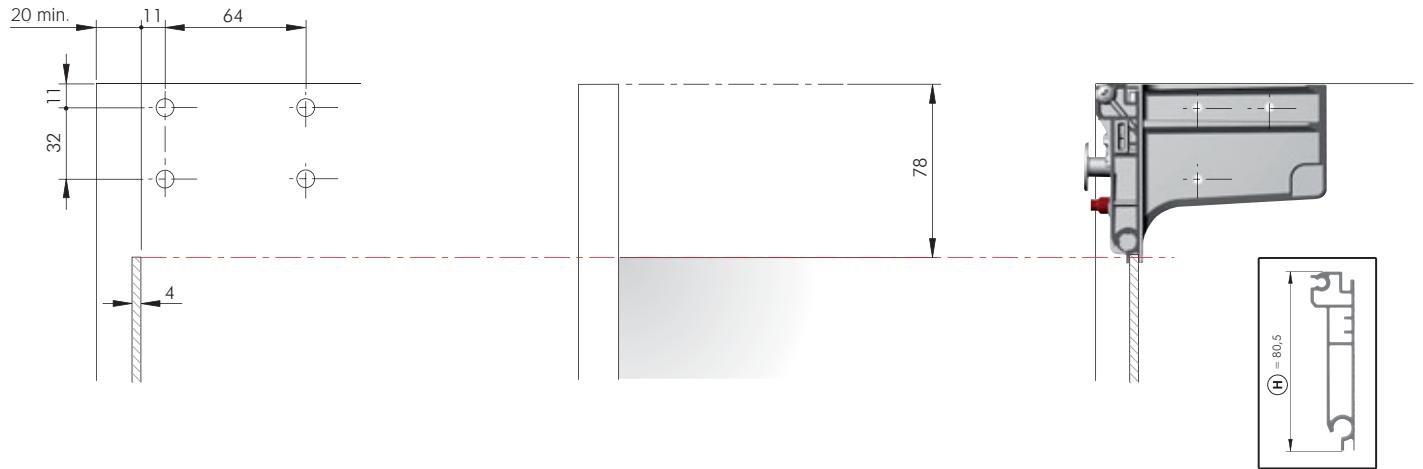

	= PZ2	
ZA	ST	= 50 pcs.
63422200ZN		
63422210ZN		



LIBRA H7 ALUMINIUM BAR H. 40,2

TO BE CUT BY THE CUSTOMER



AL			
		H	L
6700000000		40,2	4000

Optional pre-drilling operation/s to be carried out by the customer.

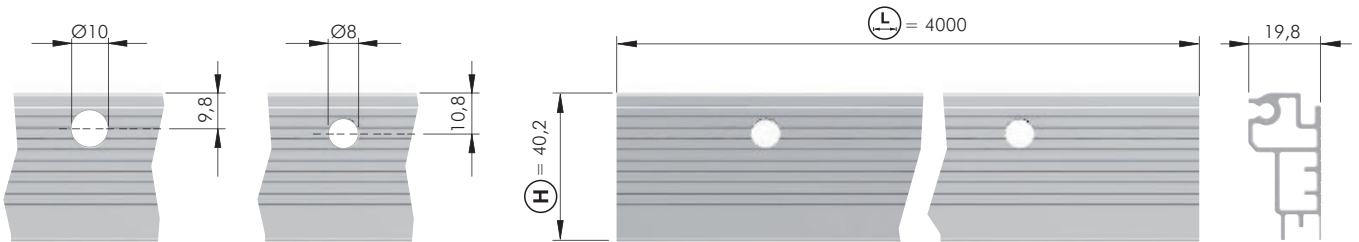

LIBRA H7 ALUMINIUM BAR H. 80,5

TO BE CUT BY THE CUSTOMER



AL			
		H	L
6710000000		80,5	4000

Optional pre-drilling operation/s to be carried out by the customer.

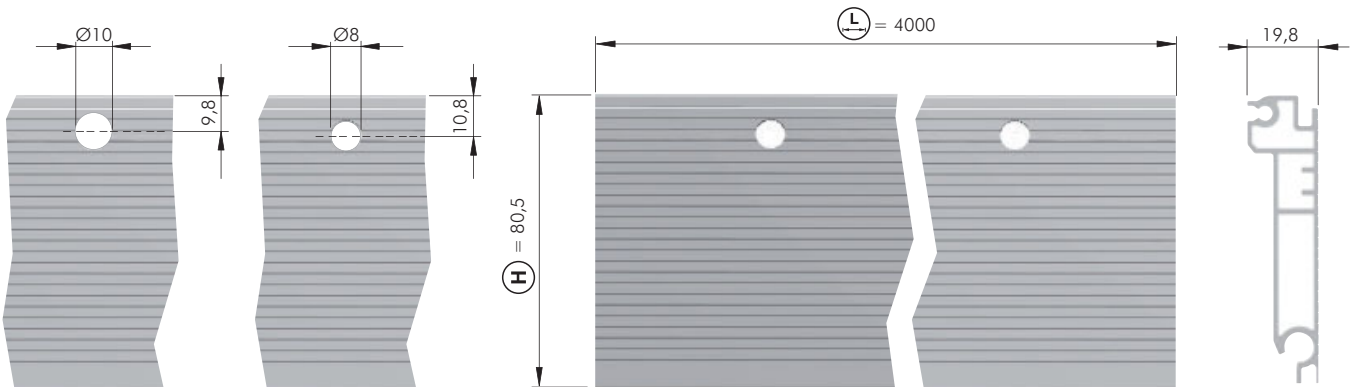

LIBRA H7 ALUMINIUM BAR H. 40,2 AND H. 80,5 WITHOUT END ELEMENTS

TO BE CUT BY THE CUSTOMER

SUGGESTED POSITIONING OF PRE-DRILLED Ø 8 OR Ø 10 INTERMEDIATE PILOT HOLES ACCORDING TO CABINET WIDTH

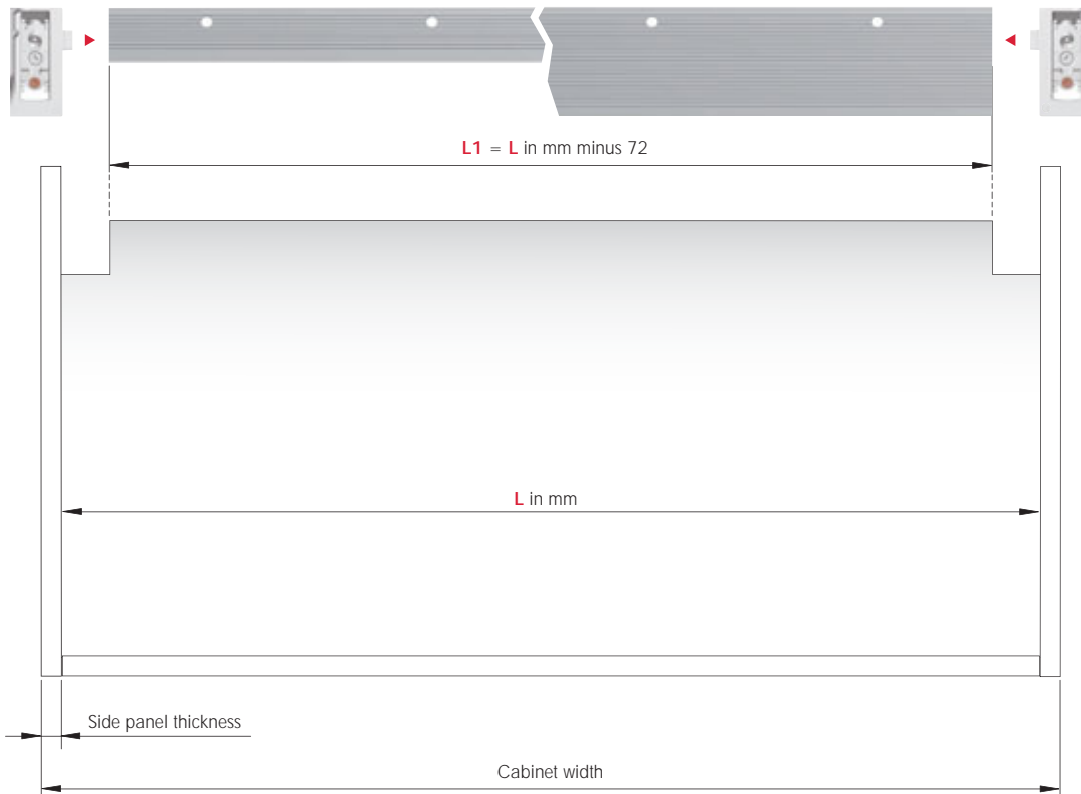

SUGGESTED COMBINATIONS:

CABINET WIDTH (mm)	INTERMEDIATE PILOT HOLES
up to 450	-
from 451 to 600	1
from 601 to 950	2
from 951 to 1200	3
over 1201	4

Cabinet width over 1201

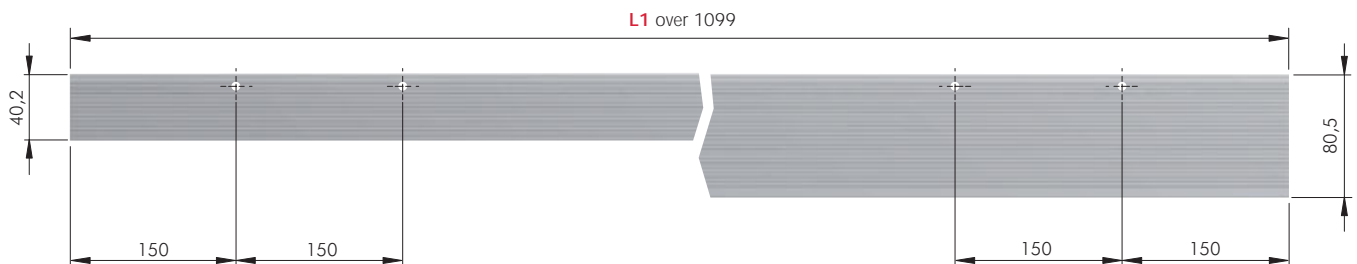

CABINET WIDTH OVER 1201

SIDE PANEL	L1
15	1099
16	1097
18	1093
19	1091



Cabinet width from 951 to 1200

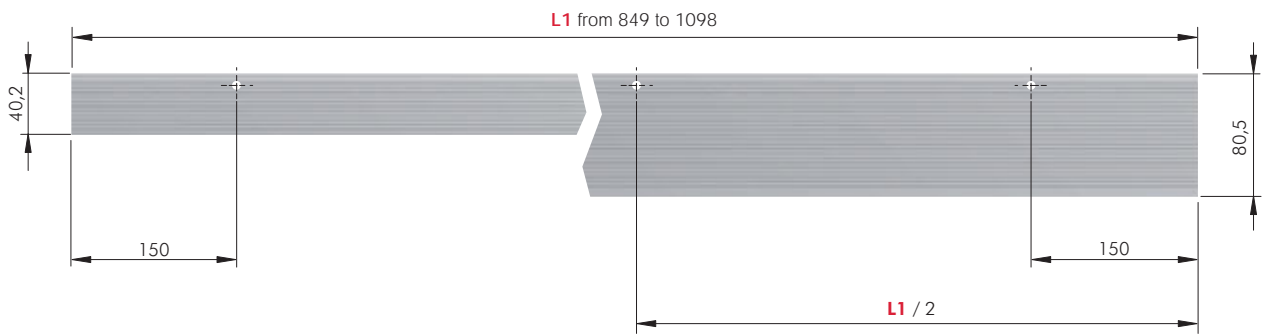

CABINET WIDTH from 951 to 1200

SIDE PANEL	FROM - TO
15	849 - 1098
16	847 - 1096
18	843 - 1092
19	841 - 1090

Cabinet width from 601 to 950

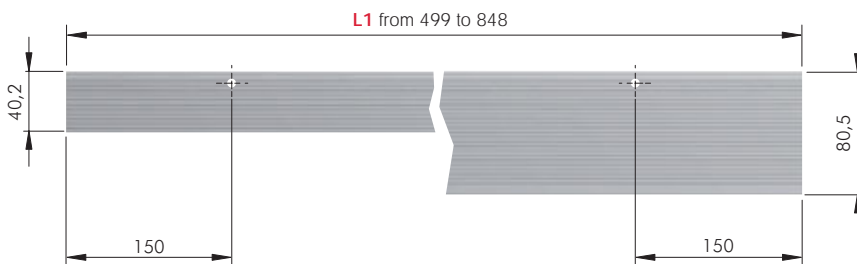

CABINET WIDTH from 601 to 950

SIDE PANEL	FROM - TO
15	499 - 848
16	497 - 846
18	493 - 842
19	491 - 840

Cabinet width from 451 to 600

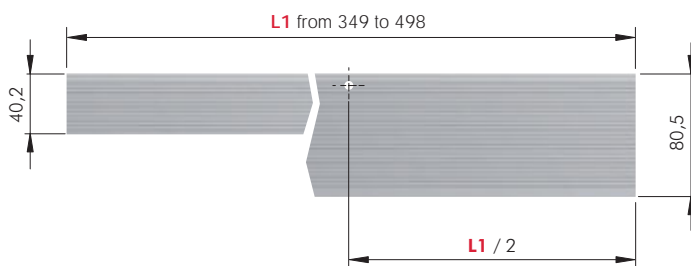

CABINET WIDTH from 451 to 600

SIDE PANEL	FROM - TO
15	349 - 498
16	347 - 496
18	343 - 492
19	341 - 490

Cabinet width 450

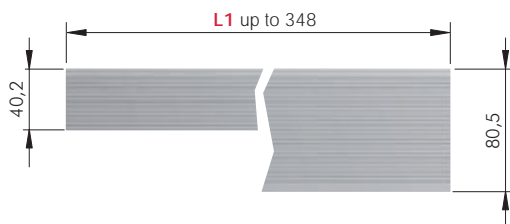

CABINET WIDTH 450

SIDE PANEL	L1
15	348
16	346
18	342
19	340

LIBRA H7 ALUMINIUM BAR H. 40,2 WITHOUT END ELEMENTS: CUT ON SIZE WITH PRE-DRILLED Ø 8 INTERMEDIATE PILOT HOLES

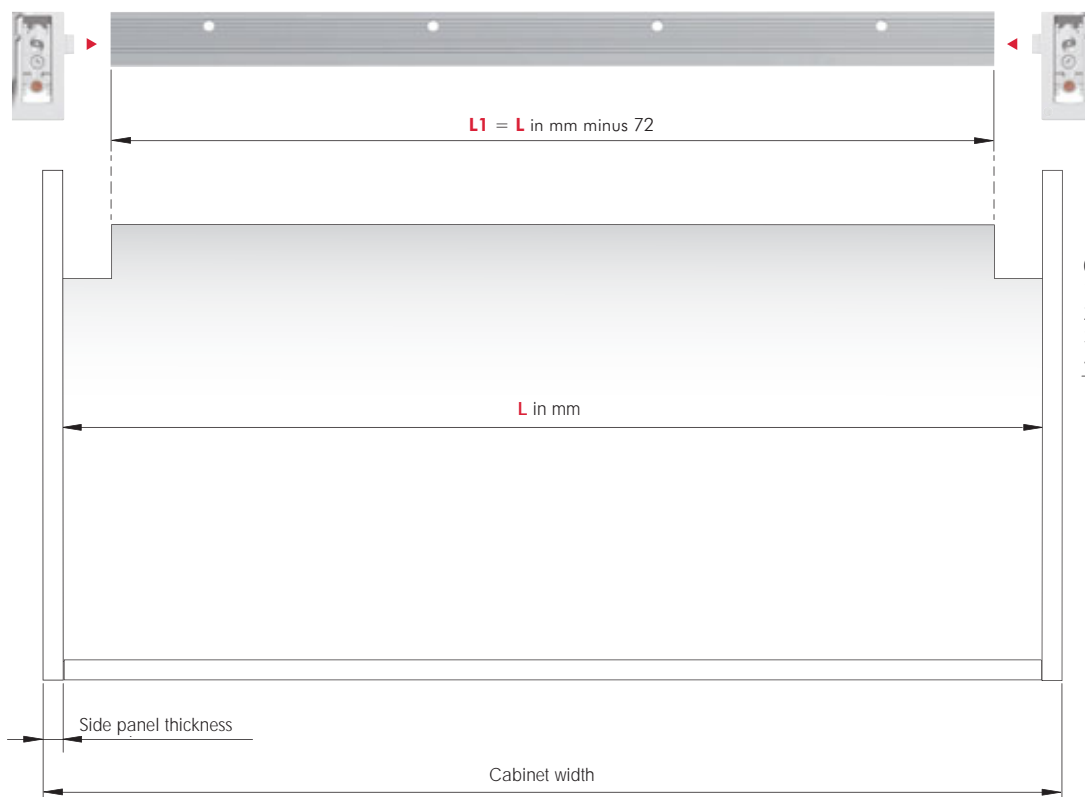

L1
670XXXXY00

- 0 = without intermediate pilot hole
- 1 = with 1 intermediate pilot hole
- 2 = with 2 intermediate pilot holes
- 3 = with 3 intermediate pilot holes
- 4 = with 4 intermediate pilot holes

SUGGESTED COMBINATIONS:

CABINET WIDTH (mm)	INTERMEDIATE PILOT HOLES
up to 450	-
from 451 to 600	1
from 601 to 950	2
from 951 to 1200	3
over 1201	4

LIBRA H7 ALUMINIUM BAR H. 80,5 WITHOUT END ELEMENTS: CUT ON SIZE WITH PRE-DRILLED Ø 8 INTERMEDIATE PILOT HOLES

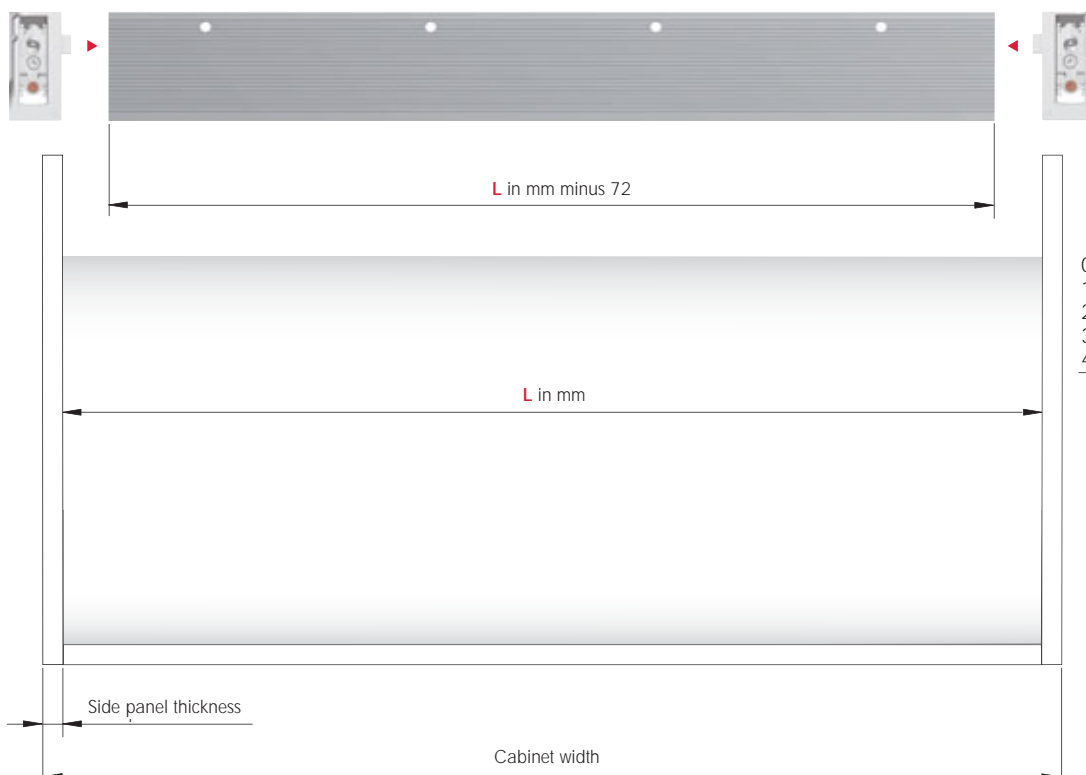

L in mm minus 72
671XXXXY00

- 0 = without intermediate pilot hole
- 1 = with 1 intermediate pilot hole
- 2 = with 2 intermediate pilot holes
- 3 = with 3 intermediate pilot holes
- 4 = with 4 intermediate pilot holes

SUGGESTED COMBINATIONS:

CABINET WIDTH (mm)	INTERMEDIATE PILOT HOLES
up to 450	-
from 451 to 600	1
from 601 to 950	2
from 951 to 1200	3
over 1201	4



LIBRA H7 DOWEL FIXING ACCESSORY

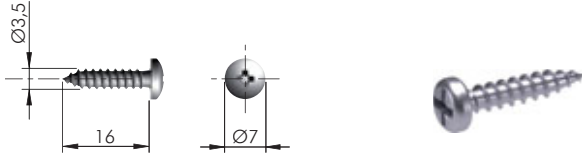

		= PZ2	
ST	= on request		
60103140ZN			

LIBRA H7 H. 40,2 AND H. 80,5 ALUMINIUM BAR FIXING ACCESSORY

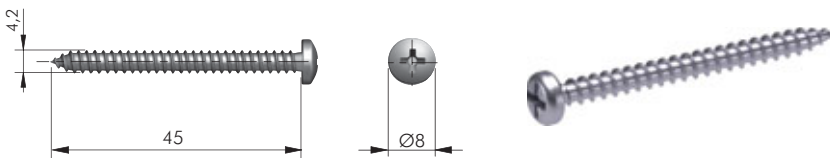

		= PZ2	
ST	= on request		
60203540ZN			

LIBRA H7 H. 80,5 ALUMINIUM BAR FIXING ACCESSORY

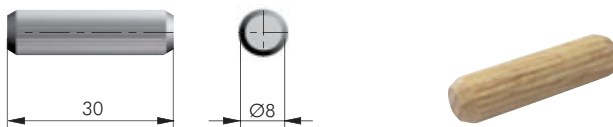

WD	= on request		
6110001000			

SPACERS FOR LIBRA H7 ALUMINIUM BAR H. 80,5

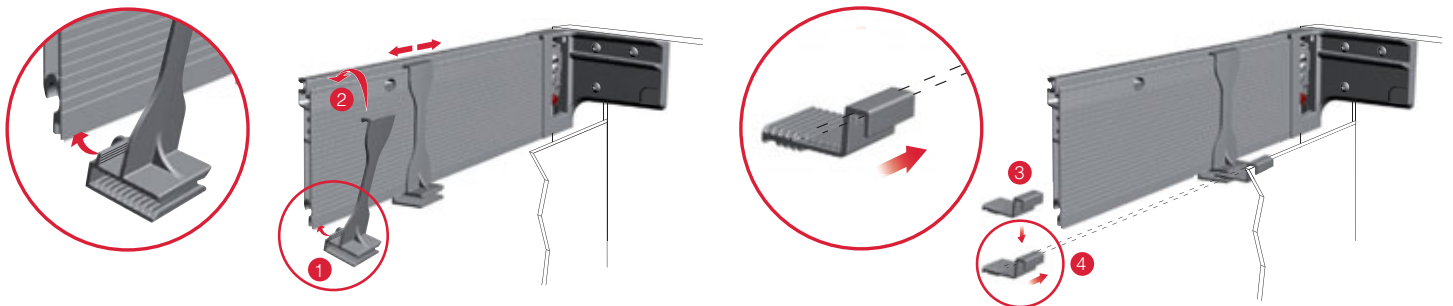

SPACER K

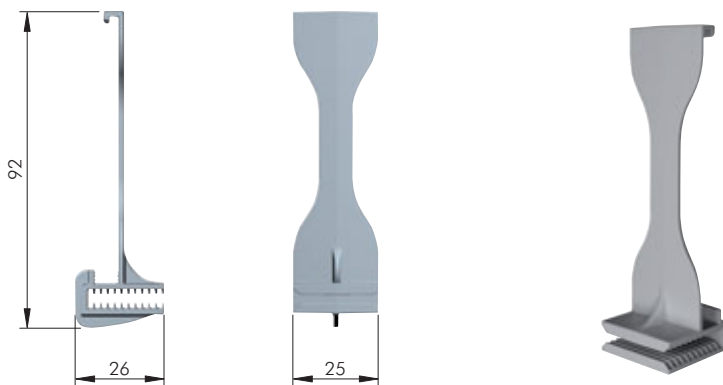

EP	= 600 pcs.
123	
63490520IJ	

SPACER K36, 36-50 mm

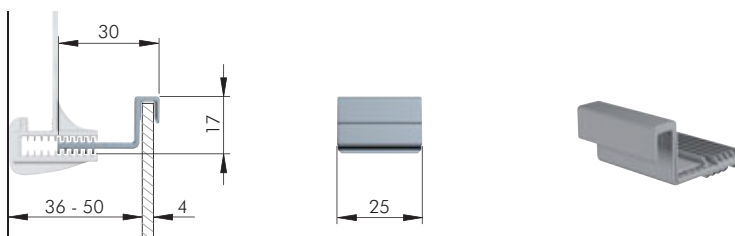

EP	= 1500 pcs.
123	
63490530IJ	

SPACER K47, 47-71 mm

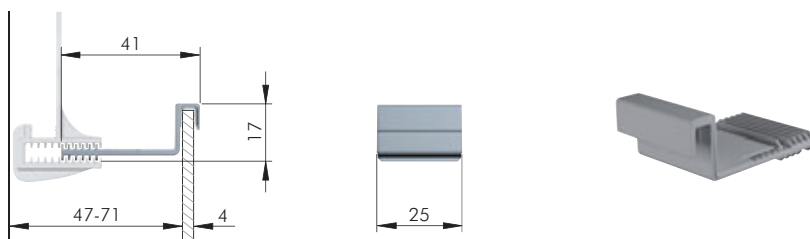

EP	= 1500 pcs.
123	
63490540IJ	



OPTIONAL VERSION

LIBRA H7 DOWEL FIXING WITHOUT "PEG JOINT"

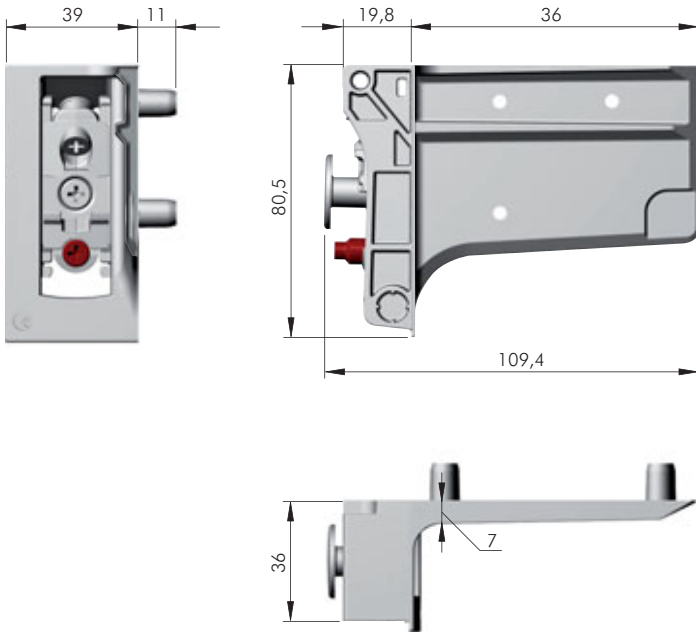

= PZ2			= 50 pcs.
63422220Z N			
63422230Z N			

SIDE PANEL 15 MIN

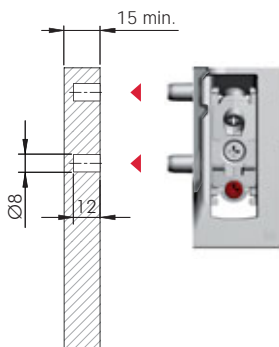

DRILLING PLAN WITHOUT BACK PANEL

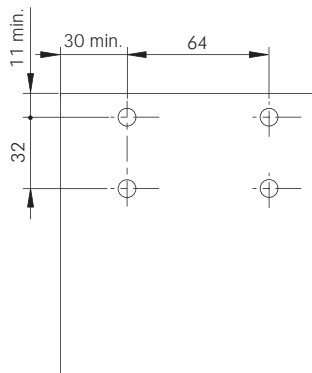

DRILLING PLAN WITH BACK PANEL WOOD THICKNESS 4 - 14 MM

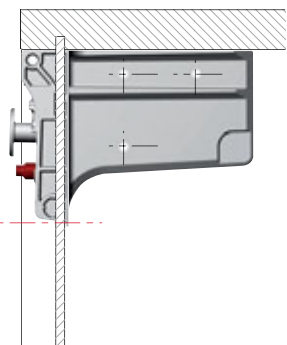
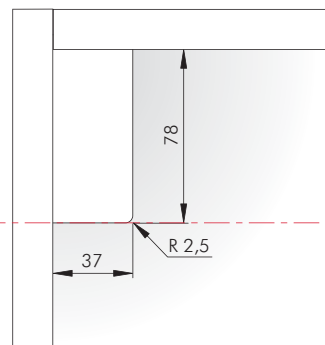
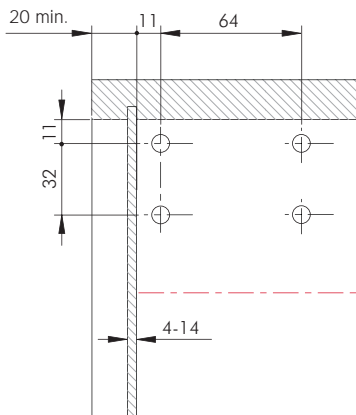

DRILLING PLAN WITH BACK PANEL WOOD THICKNESS 4 MM AND H. 40,2 MM ALUMINIUM BAR

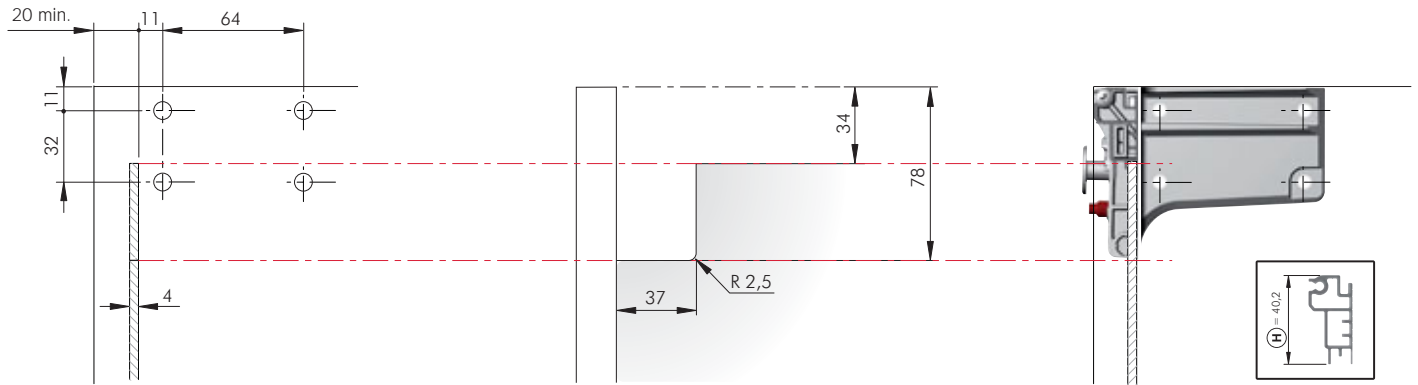

DRILLING PLAN WITH BACK PANEL WOOD THICKNESS 8 MM AND H. 40,2 MM ALUMINIUM BAR

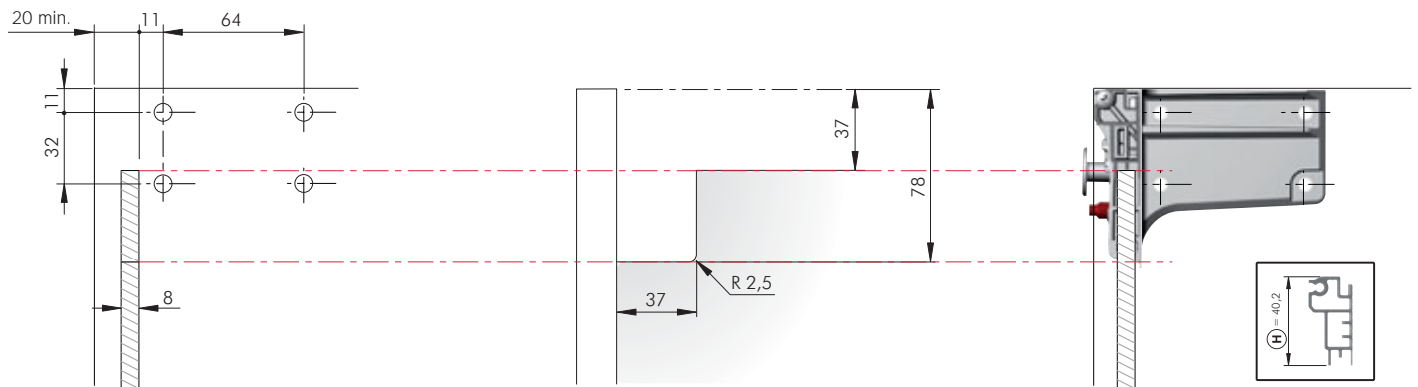

DRILLING PLAN WITH BACK PANEL WOOD THICKNESS 4 MM AND H. 80,5 MM ALUMINIUM BAR

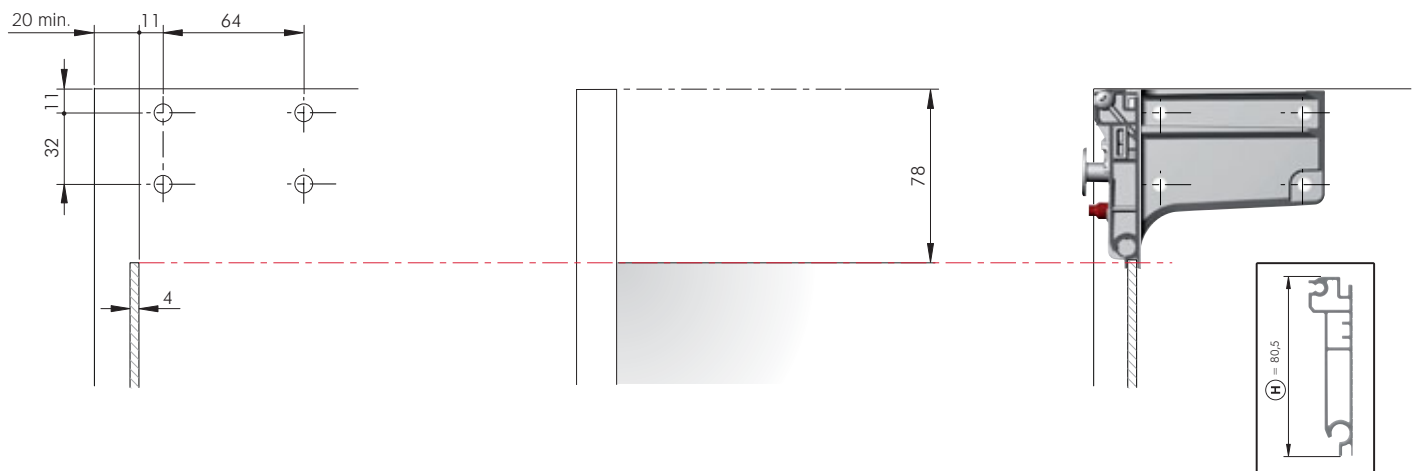



OPTIONAL VERSION

LIBRA H7 SCREW FIXING WITH "PEG JOINT" FOR ALUMINIUM BAR



Certificates available on request.

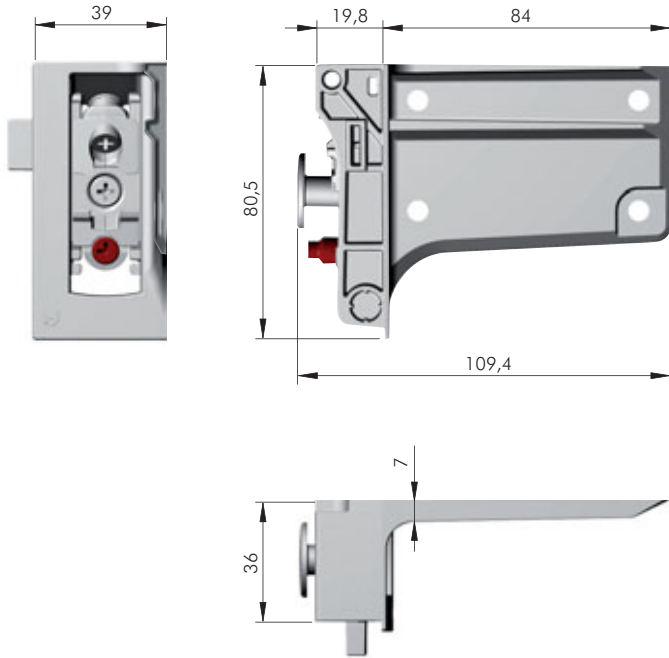

	= PZ2				= 50 pcs.
		63422240ZN	(R)		
		63422250ZN	(L)		

SIDE PANEL 15 - 16 MM THICK

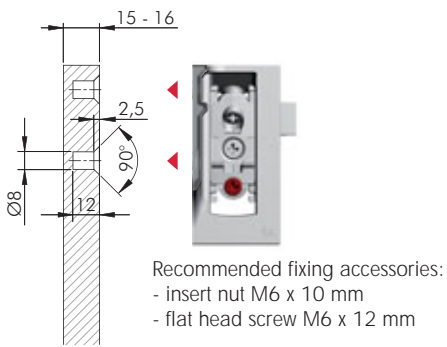

SIDE PANEL 18 - 19 MM THICK

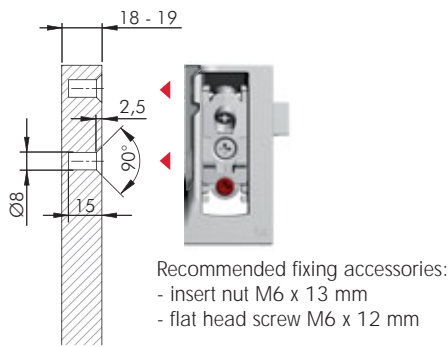

DRILLING PLAN WITHOUT BACK PANEL

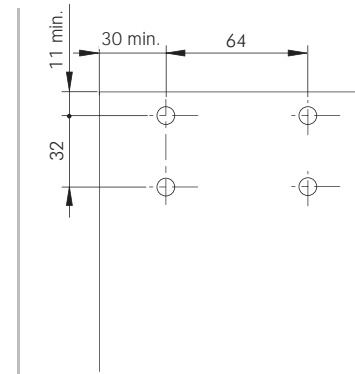

DRILLING PLAN WITH BACK PANEL WOOD THICKNESS 4 MM

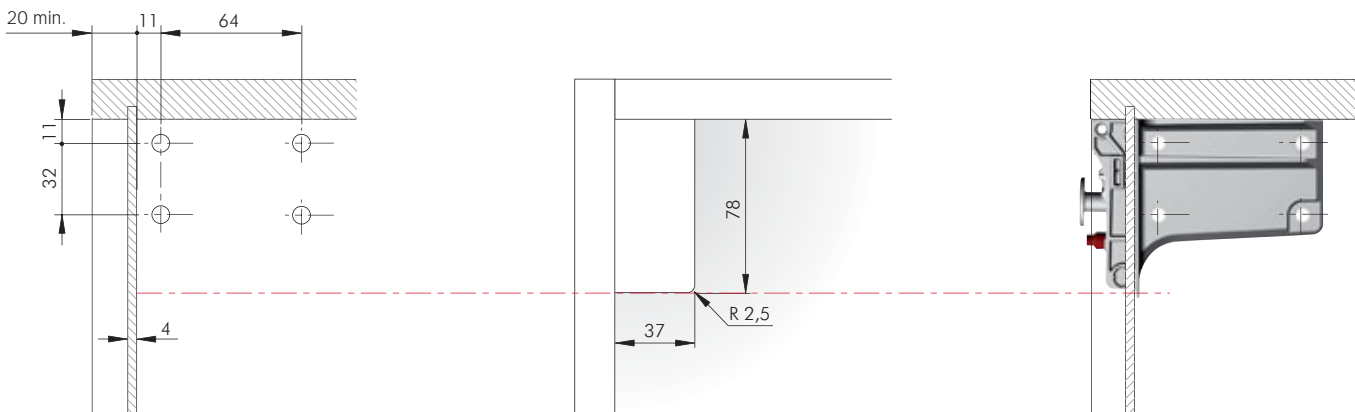

LIBRA H7 INTEGRAL COVER

INSTALLATION

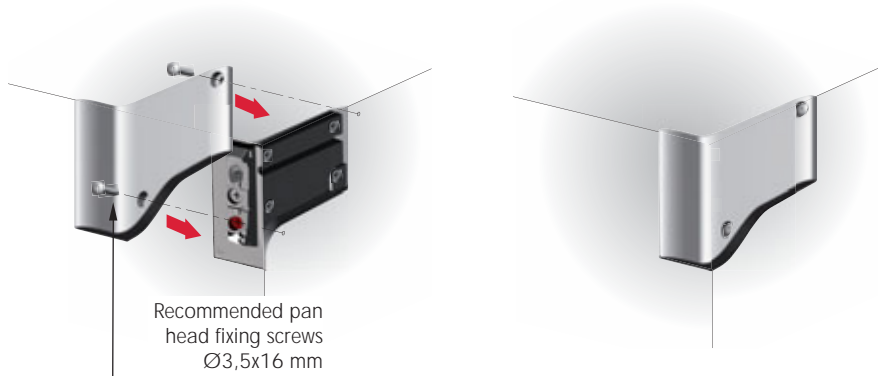

Recommended pan head fixing screws
Ø3,5x16 mm

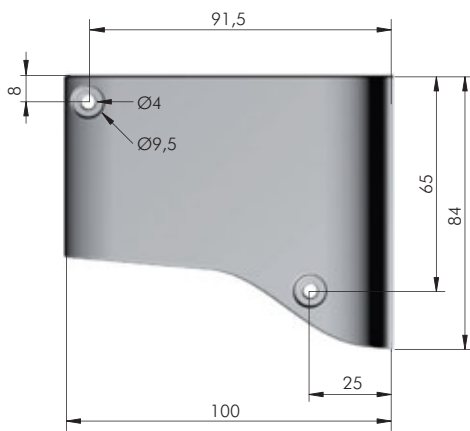

EP	= 200 pcs.	
63490620AB	(R)	
63490610AB	(L)	
63490620EE	(R)	
63490610EE	(L)	
63490620IJ	(R)	
63490610IJ	(L)	

COVER CAP FOR LIBRA H7 ADJUSTMENTS

INSTALLATION

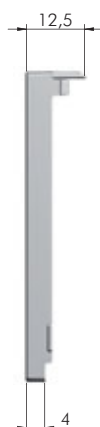
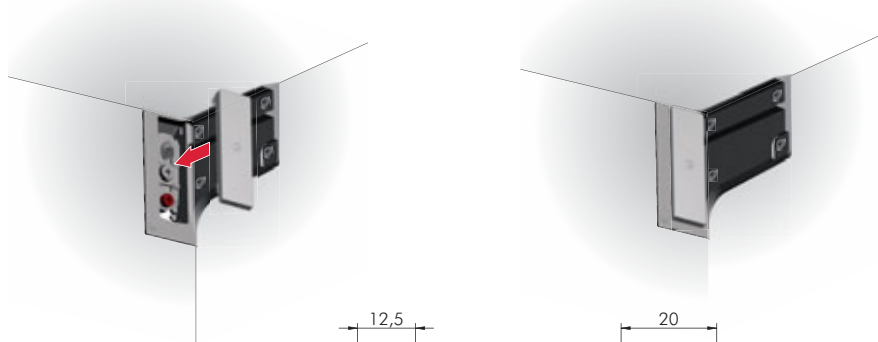

EP	= 1000 pcs.	
63490600AB		
63490600EE		
63490600IJ		

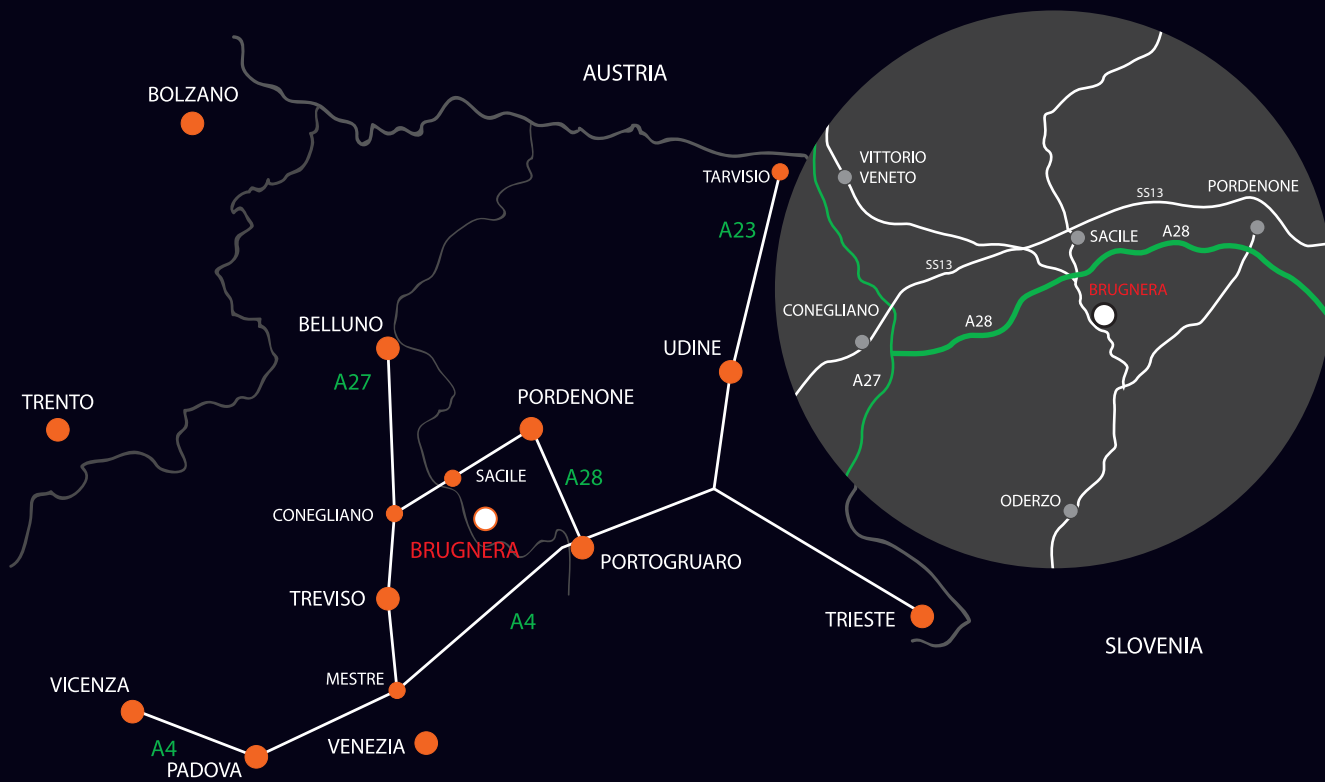

www.italianaferramenta.com